

INSTALLATION INSTRUCTIONS

DESCRIPTION: Poly Windshield Kit
 PART NUMBER: BG4-F83J0-V0
 MODEL: '18~ Wolverine X4



⚠ WARNING

Please read and understand these instructions completely before installation to avoid possible injury, or damage to the accessory or vehicle.

- **Remove this accessory if you intend to tow this vehicle because this accessory is not designed for use at highway speeds without the hard top.**
- Both sides of windshield can get dirty quickly in dusty or muddy conditions. When operating in such conditions, carry fresh water and towels to clean the windshield if vision becomes impaired. Driving with impaired vision can result in an accident.

WARRANTY INFORMATION:

See your Yamaha dealer for a copy of the warranty statement.

DEALER OR INSTALLER:

These instructions contain important information for future reference and *must* be given to the customer.

NOTICE:

This installation requires a torque wrench and should be performed by an authorized Yamaha dealer or other qualified technician.

PARTS LIST:

No.	Part Number	Description	Qty
--	BG4-F83J0-V0	Poly Windshield Kit	--
①	*	Windshield w/Top and Bottom Bulb Seals	1
②	BG4-F72C2-V0	Clamp	4
③	*	M6x16mm Button Head Hex Socket	8
④	*	M6 Washer	8

* Part supplied with kit only and not available separately.

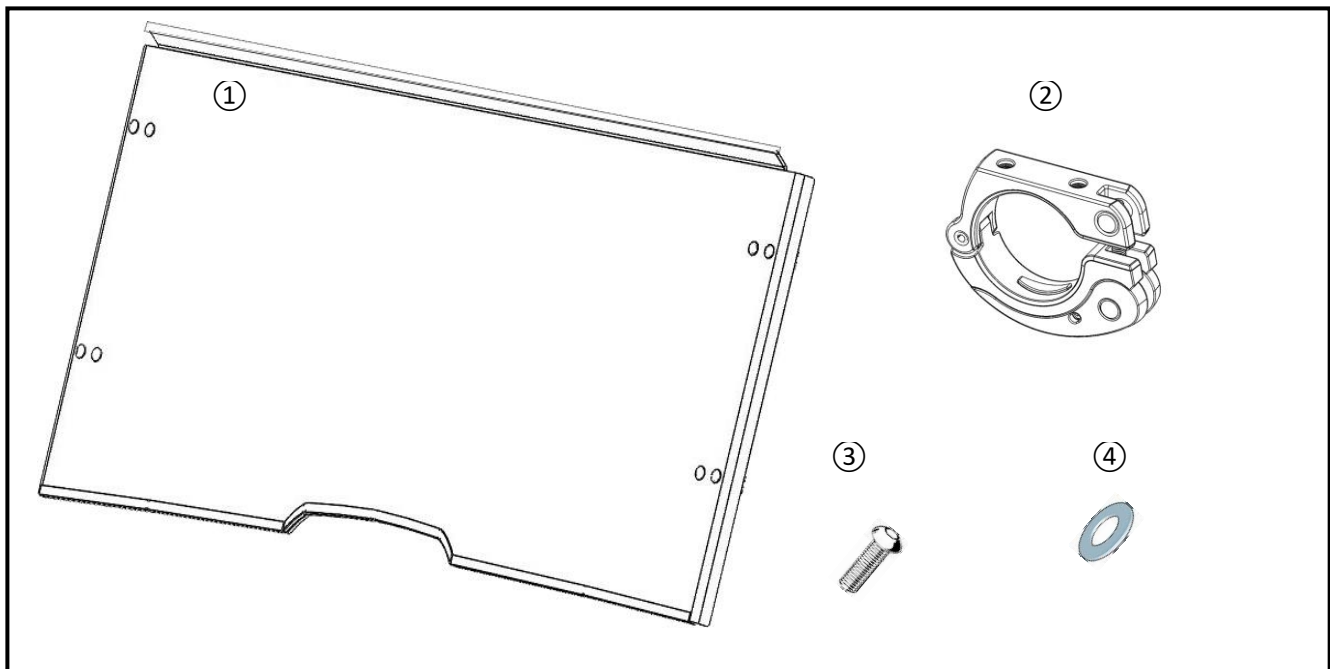

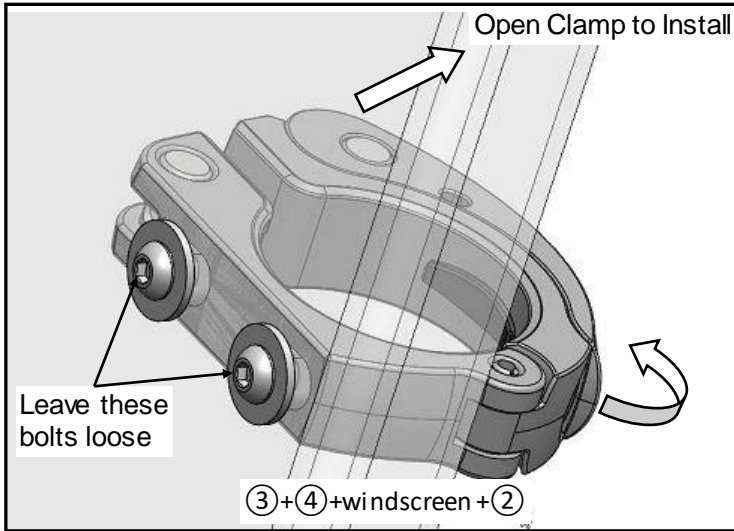

PREPARATION:

- Place the vehicle on a secure and level surface.
- Set the parking brake.
- Clean the mount surfaces before starting installation.

INSTALLATION:

1. Assemble 4 clamps to windscreen. Leave the bolts loose enough to allow the clamps to move a bit during installation. See Fig. 1.
Note: Ensure the clamps open as shown in Fig. 1
2. Install Windscreen to ROPS. Leave clamps loose. Push down to seat windscreen in channel on hood as shown in Fig. 2
3. Ensure that the top of the bulb seal on the windshield seals underneath the suntop as shown in Fig. 3
4. When you are satisfied with the position of the windscreen, close the Clamps.
5. If a clamp is too tight or too loose, open and rotate the latch handle cam until the clamp has proper tension when secured. (Fig 4)
6. Torque all bolts to 6Nm.
7. Should the windshield become damaged, cracked, etc enough to impair vision, the windshield can be clamped to the rear ROPS tubes for TEMPORARY stowage. If the BG4-K750A-V0 Soft Rear Window is installed, it must be removed prior to attaching windshield. See Fig.5.

CAUTION:

Windshield may only be mounted in the front position during towing and when used in conjunction with the hard roof. Failure to use in conjunction with the hard roof may result in cracking and failure of screen at highway speeds.

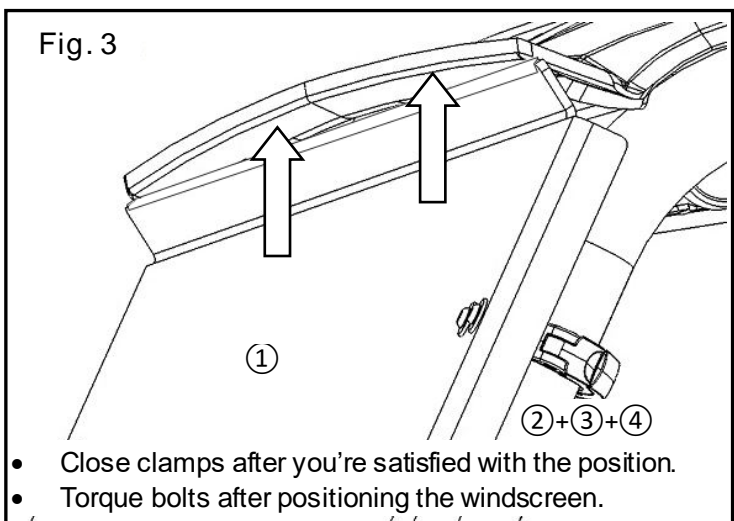
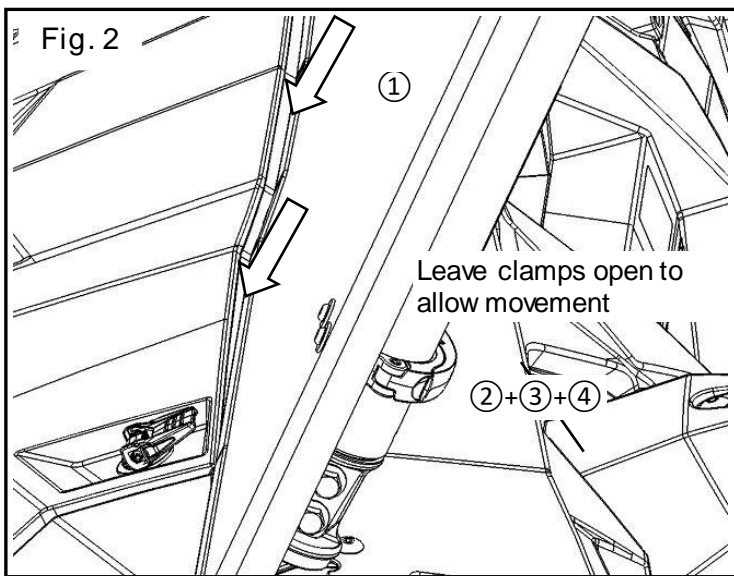

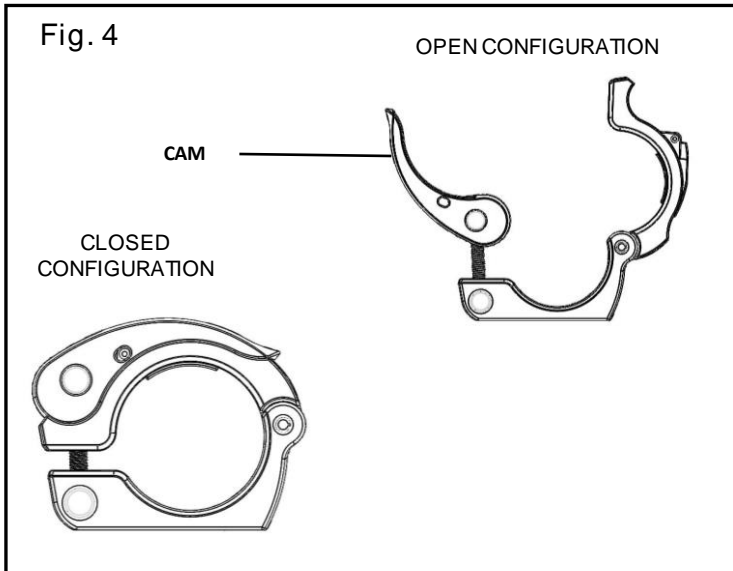

MAINTENANCE:

Periodically, check torque and tightness on all hardware. If loose hardware is found, re-torque or re-tighten.

CARE AND CLEANING:

Use a clean soft cloth and mild detergent with warm water to clean the windscreen. Rinse and dry. Yamaha Windshield & Visor Plastic Cleaner & Conditioner (p/n ACC-PLASP-OL-11) is recommended to clean the windscreen.

CUSTOMER SERVICE:

This part is not for use with BG4-K750A-T0 Glass Rear Window. For further information see your Yamaha dealer.

ESTIMATED TIME TO INSTALL: 0.3 HR

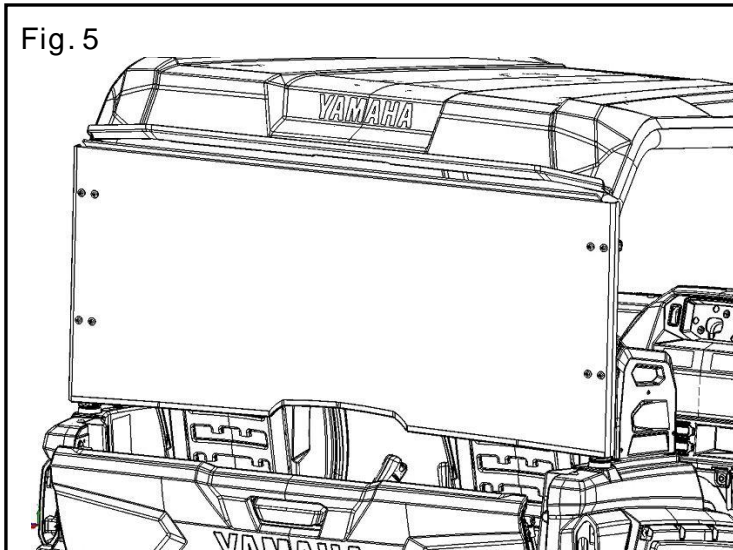

⚠ WARNING

Do not exceed 15mph with the windscreen in this position. Do not tow/trailer the vehicle with the windshield in this position. (Fig 5)